

Weighing System Surge Protector

FEATURES

- Protects measuring equipment and load cells from damage caused by lightning, heavy electrical load switching, etc.
- Suitable for AC or DC excitation voltages
- No influence on system accuracy;
EC certified to EN45.501, "8.1"
- Automatic reset function
- Housed in a fully sealed waterproof enclosure
- Can be used in EEx(i) systems without further certification

APPLICATIONS

- Weighbridges

DESCRIPTION

The LC30 Surge Protection Device protects weighing systems and load cell installations from possible malfunction and damage caused by severe over-voltages or high impulse currents on signal cabling.



Potentially destructive surges can be generated from a variety of sources, including lightning, power cable faults and heavy electrical load switching.

The advanced triple stage protection concept used in the LC30 removes the need for additional earthing systems, therefore simplifying installation and reducing cost.

OUTLINE DIMENSIONS in millimeters

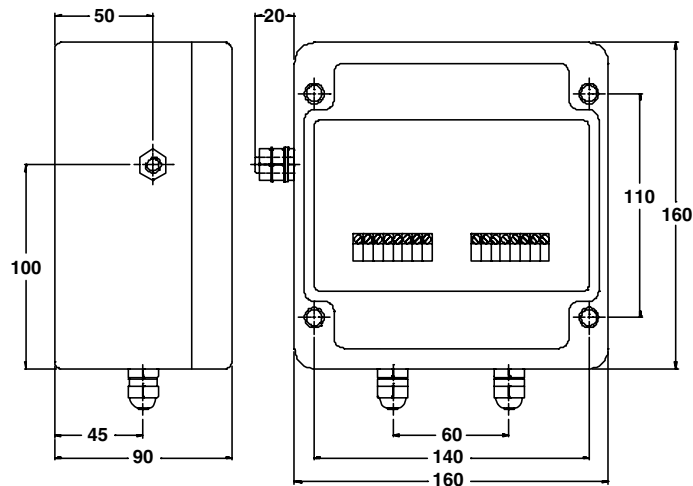

Mounting; internal 7mm diameter, through-holes.

Weighing System Surge Protector

SPECIFICATIONS		
PARAMETER	VALUE	UNIT
Nominal excitation voltage	10–15	VAC/VDC
Maximum excitation voltage ¹	22	VAC
Maximum excitation voltage ¹	32	VDC
Series resistance	≤1	Ω
Minimum impedance ²	55	Ω
Minimum signal level ²	1	μV/d
Leakage current at 32 VDC	≤10	μA
Peak impulse current (8/20 μs)	10	kA
Let-through voltage (after 6 kV/3 kA IEC801.5 comb. wave test)	80	V
Compensated temperature range	–10 to +40	°C
Operating temperature range	–20 to +60	°C
Storage temperature range	–30 to +70	°C
Humidity	5–95 (Non-condensing)	%RH
Sealing (to IEC 529 / DIN 40.050)	IP65	
Connections	Input/Output/Sense + Earth	
Max. terminal conductor size	1.5	mm ²
Main earth connection	M8 external stud	
Weight	1.5	kg

⁽¹⁾ Symmetrical to ground

⁽²⁾ For approved systems only

All specifications subject to change without notice.

The LC30 protects the system at the point of installation. A system is likely to have at least one LC30 installed at the load cell network and a secondary LC30 in the weighing control room. Additional protection should also be provided for the main power supply and any other system interconnected with the weighing package, e.g., remote computer links, data-communications via telephone lines, etc.

Typical weighbridge system connections:

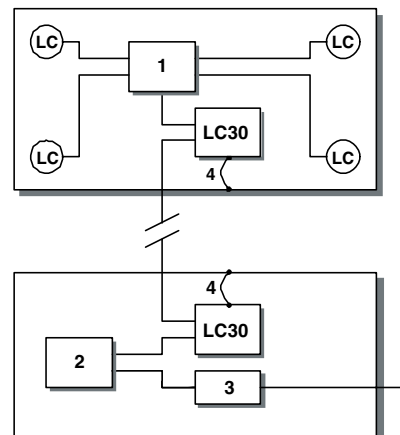

- 1: Junction box
- 2: Measuring device or indicator
- 3: Additional power supply protection
- 4: Local structural bond